

18 LED Thru-Hull SeaLite[®]

U.S. Patent No. 7,044,623

Installation, Operation, Maintenance and Safety Instructions

18 LED Manual P/N 712-004-601-0A



4033 Ruffin Rd., San Diego, CA 92123-1817, Phone: (858) 576-1261, Fax: (858) 576-0219
E-mail: info@deepsea.com Web: www.deepsee.com

Table of Contents

UNPACKING AND INSPECTION	3
MANUAL INFORMATION	4
 READ BEFORE USING THE 18 LED THRU-HULL SEALITE®	5
18 LED THRU-HULL SEALITE® FEATURES.....	6
SPECIFICATIONS	7
PARTS OF THE 18 LED THRU-HULL SEALITE®	8
INSTALLATION INSTRUCTIONS.....	9
OPERATING INSTRUCTIONS.....	11
MAINTENANCE AND TROUBLESHOOTING	12
Troubleshooting Guide	12
Internal Fuse Replacement.....	13
Replacing Driver Assembly.....	14
HOW TO ARRANGE FOR REPAIRS	16
Warranty Repairs.....	16
Non-Warranty Repairs	16
LIMITED WARRANTY	16
APPENDIX A – DRAWINGS	18
Figure 1 – Wiring Diagram.....	19
Figure 2 – Assembly Drawing.....	20
Figure 3 – Detail: Driver Heatsink Clamp cutaway	21

Congratulations on the purchase of your 18 LED Thru-Hull SeaLite®! DeepSea Power & Light has been supplying underwater lights for industrial and research applications for over 25 years, and our line of SeaLite® products have set the standard for durability and performance in every industry where they are used. Your 18 LED Thru-Hull SeaLite® has been rigorously tested, and the quality and performance of your product comes with the full confidence and backing of DeepSea Power & Light. As a measure of that confidence, your 18 LED Thru-Hull SeaLite® comes with a full one-year warranty against defects in workmanship and materials. A complete copy of the warranty statement can be found on page 13.

Unpacking and Inspection

Before the 18 LED Thru-Hull SeaLite® is packaged for shipment it is rigorously tested and inspected. The product is then carefully packaged to withstand the rough handling that can be anticipated during shipment. DeepSea Power & Light engages only reputable shipping companies to handle our merchandise, so it is rare that a product is damaged in shipment. Upon arrival, carefully check the light for damage. If the product is damaged in any way, immediately file a damage claim with the carrier. In addition, mail or fax a copy of the claim to DeepSea Power & Light and notify your sales representative. We will do everything in our power to expedite processing of the claim.

18 LED Thru-Hull SeaLite®	
Record the Serial Number of your unit below and retain for your records.	
Serial Number	

Manual Information

The following symbols and terms are used throughout this manual to emphasize important safety information.



is used to highlight important information.



Caution! is used to indicate directions that, if not followed correctly, can result in equipment damage.



WARNING! is used to indicate directions that, if not followed correctly, can result in personal injury and/or serious equipment damage.



DANGER! is used to warn of directions that, if not followed correctly, can result in serious personal injury or death.



Read Before Using the 18 LED

Thru-Hull SeaLite®

1. 18 LED Thru-Hull SeaLites® are designed for installation on fiberglass and wooden hulled boats only.
2. 18 LED Thru-Hull SeaLites® should never be installed on a vessel while the vessel is in the water.
3. The wall thickness surrounding any part of the thru-hull fitting should not be less than 0.25 in (6.35 mm) and not more than 5 in (127 mm).
4. Only qualified technicians who have experience with the installation of thru-hull fixtures should install 18 LED Thru-Hull SeaLites®.
5. 18 LED Thru-Hull SeaLites® must be electrically joined to the vessel's grounding and cathodic protection system. Failure to properly ground this fixture may result in catastrophic failure due to CORROSION, which in turn may lead to injury, damage or loss of property and loss of life.



WARNING! It should be noted that all metal parts will corrode in salt water. Corrosion of any metal will be especially aggressive if installation is improper, if bonding is improper, or if stray currents are active in the vicinity of the boat. 18 LED Thru-Hull SeaLites® are warranted to be free from defects in material and workmanship, but this does not extend to being completely free from corrosion since the primary factors affecting corrosion are outside of the scope of material and workmanship of the light itself.

6. Once the fixtures have been installed on the vessel they should be inspected every 6 months for:
 - a. Corrosion and damage. Any fixture showing signs of corrosion or other physical damage should be removed from service immediately.
 - b. Signs of leakage and water entry. Any fixture showing signs of leakage or water entry should be removed from service immediately.
 - c. Blackened or opaque ports. The light should never be operated with a blackened or opaque port. If the port is blackened the fixture should not be operated and should be inspected for internal damage.
 - d. Marine growth on the port. Any marine growth should be removed from the port in order to allow heat and light to exit the fixture. Use of a soft brush or non-metallic household dishwashing scrubber is recommended to prevent damage to the fixture and port. If the growth cannot be removed using a soft brush, a professional hull cleaner should be consulted.

18 LED Thru-Hull SeaLite® Features

Several features come together in the 18 LED Thru-Hull SeaLite® to create a unit that offers amazing light output, is extremely rugged and most importantly, safe.

- **Ultra Long Life** – With an average life of 50,000 hours, the 18 LED Thru-Hull SeaLite® will provide many years of service. Unlike traditional lights, LEDs require no bulb maintenance!
- **18 High Color Temperature LEDs for Enhanced Effect** – Your 18 LED Thru-Hull SeaLite® projects a white, bright light from its 5,700-6,700°K color temperature LEDs. Each of the 18 LEDs has its own reflector to distribute the light for maximum effect. Blue and green LED color options are available.
- **316 Stainless Steel Construction** – The thru-hull fitting is manufactured from 316 Stainless Steel for enhanced corrosion protection.
- **High Performance Polymer Port** – Our exclusive polymer port will withstand accidental impact better than glass, and is less likely to be damaged by hull cleaning equipment.
- **Water-tight Housing** – Two front seals and two rear seals provide an extra measure of safety. In the unlikely event that the port is broken, the rear seals will contain flooding to the inside of the thru-hull fitting. No water is allowed into the vessel.
- **Integrated Driver Board** – The driver board and all electronic circuitry is integrated into the watertight housing, protecting it from the elements and simplifying installation. Simply run the power cable from the back of the light to your power source.
- **Serviceable From Inside The Boat** – Once installed, the LEDs and driver can be accessed thru the back of the light. Hauling out is not required!
- **Thermal Compensation Circuitry** – Special circuitry regulates the temperature of the LEDs, improving the life of the LEDs and allowing the light to be run in air.

Specifications

Light Specifications

MECHANICAL	
Housing Material:	316L Stainless Steel
Pressure Tested To:	100 PSI
Size:	
Length:	8.73 in. (22.17 cm)
Diameter:	
Thru-Hull Fitting:	2.95 in. (7.49 cm)
Outer Flange (1/4 in. thick):	5.0 in. (12.70 cm)
Weight:	7.00 lb. (3.18 kg)
Lens:	High performance polymer
Cable Length:	15' (4.57 m) standard (longer available on request)
Recommended Hull Thickness:	
Minimum:	1/4 in. (6.35 mm)
Maximum:	5.0 in. (12.70 cm)

LAMP	
Type:	LED
Rated Average Life:	50,000 hours
Color Temperature:	5,700-6,700° K (Cool white, green and blue)
Beam Angle:	17° center spot within 90° flood

OPERATING	
Warm Up / Re-strike Time	Instantaneous
Minimum Operating Temperature:	-22° F (-30° C)

ELECTRICAL	
Input Voltage:	10-32 VDC
Input Current:	4.3A at 12V
Wattage:	52 Watts

Parts of the 18 LED Thru-Hull SeaLite®

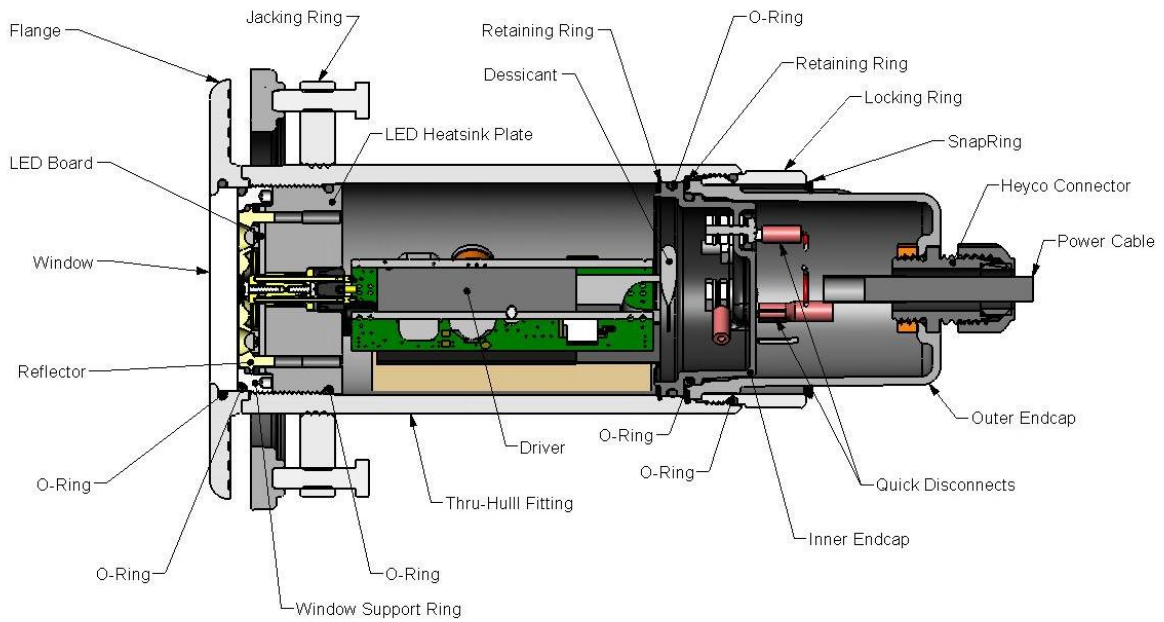

Installation Instructions



Your 18 LED Thru-Hull SeaLite® is designed for installation in fiberglass and wooden hulled boats only. Only qualified technicians who have experience with the installation of thru-hull fixtures should install 18 LED Thru-Hull SeaLites®.



Caution! For hulls constructed with Divinycell® or similar foam cores, please consult the boat manufacturer, a professional boat builder, or your boat dealer for specific procedures to use when installing hull-penetrating fixtures. In general, the exposed surfaces of the internal core must be protected using a fiberglass resin or an epoxy compatible with the hull material to form a solid, sealed surface from the outside to the inside of the hull. This material must be rated to no less than 176°F (80°C).

18 LED Thru-Hull SeaLites® are typically mounted horizontally in the transom, however, they can also be installed horizontally through the side of the hull and vertically down through the hull. Performance for vertical installations varies depending on the installation and water conditions. While vertical installations work successfully much of the time, there are conditions which can cause the light to run hotter than normal. In particular, down pointing lights in still water are apt to get air bubbles on the flange and window that degrade heat transfer. If a down pointing light is running hotter than normal, the thermal compensation circuitry will dim down the LEDs to regulate the temperature.

1. The 18 LED Thru-Hull SeaLite® should be mounted on a flat part of the hull with the center of the fitting at least 10" (254 mm) below the waterline. The fitting's flange should not extend beyond the flat surface on which it will be mounted.
2. To ensure no damage has occurred during shipping, power up the unit BEFORE drilling any holes in the boat. Before cutting the hole, ensure that there will be a minimum clearance of 16" (406 mm) on the inside of the hull, inboard of the hole. This clearance is necessary to allow enough room to service the light from inside the boat.
3. On the outside of the hull, mark the center of the hole to be made in the hull. Draw a 5" (127mm) circle around the center mark and verify that the area of the hull within is flat.
4. Cut or drill a 3" (76 mm) diameter hole in the hull.
5. Test fit the thru-hull fitting in the hole by sliding the fitting in from the outside of the hull.
6. Using the circle drawn on the hull in step 3 as a guide, coat the area around the hole with 3M® 4200 sealant. Also, coat the flange and the portion of the body of the fixture that will extend thru the hull with 3M® 4200 sealant and slide the fixture into the hole.



Caution! Be careful not to over-tighten the bolts when installing the jacking ring. Doing so may squeeze the sealant out from under the fitting flange.

7. On the inside of the hull, slide the jacking plate and jacking ring assembly over the thru-hull fitting to the inside of the hull. The six 1/4"-20 hex head bolts in the jacking ring should be evenly engaged in the jacking plate and there should be approximately 1/4 inch gap between the jacking ring and jacking plate. Thread the jacking assembly onto the fitting until it bottoms against the boat hull. Hand-tighten the six 1/4"-20 hex head bolts to approximately 5 in.-lbs.
8. Allow the sealant to dry (according to its instructions) and remove any excess.

9. After the sealant has dried, tighten the six 1/4"-20 hex head bolts to 36 in.-lbs (4 Nm).
10. Use the green screw terminal on the jacking ring to connect the fixture to the ship's bonding system. Failure to properly ground this fixture may result in catastrophic failure due to CORROSION, which in turn may lead to injury, damage or loss of property and loss of life.
11. DSP&L recommends that the flange of the thru-hull fitting be painted with anti-fouling paint after installation. In addition, spraying the end cap and the portion of the fitting inside the hull with WD-40 every two months will help keep the fitting looking new and free of corrosion.



Caution! The original cable provided with this light has been specifically chosen for this application. Substituting another cable may cause improper operation, shock hazard, interference with other equipment on the vessel, and can result in **damage that may not be covered under warranty.** Additional cable is available from DeepSea Power & Light, Inc. by calling 1-800-ITS-DSPL (1-800-487-3775).

12. Verify that the light's voltage rating and the voltage available on the vessel are compatible. Ensure that the DC power is turned off. Refer again to the wiring diagrams on page 16 and connect the light's cable to a properly sized in-line fuse or circuit breaker. Consult a professional marine electrician.



WARNING! DO NOT connect 18 LED Thru-Hull SeaLite® to AC voltage.

13. At this point, the 18 LED Thru-Hull SeaLite® can be tested by energizing the light.

Operating Instructions

1. To turn the 18 LED Thru-Hull SeaLite® on, apply 10-32 VDC power to the light.



WARNING! DO NOT connect 18 LED Thru-Hull SeaLite® to AC voltage.

2. The 18 LED Thru-Hull SeaLite® can function in water or in air. Thermal compensation circuitry regulates the temperature of the LEDs and will dim them down in the event that they get too warm. For example, lights mounted in the transom of a vessel may break the surface of the water while the boat is underway, causing the lights to run warmer than if they were completely submerged. If this is the case, the LEDs will be dimmed automatically to regulate the temperature.



WARNING! If the 18 LED Thru-Hull SeaLite® has been running in AIR, DO NOT submerge it while still running or hot. Allow the light to cool down for a couple of minutes before immersing it in water to minimize thermal shock.

3. To turn the 18 LED Thru-Hull SeaLite® off, turn the power to the light off.

If the light does not operate properly, please refer to the Troubleshooting Guide on page 12 to determine the cause of the malfunction.



WARNING! ALWAYS remove power to any light that is not operating properly to reduce the risk of electrically driven corrosion failure of the fitting.

Maintenance and Troubleshooting

Troubleshooting Guide

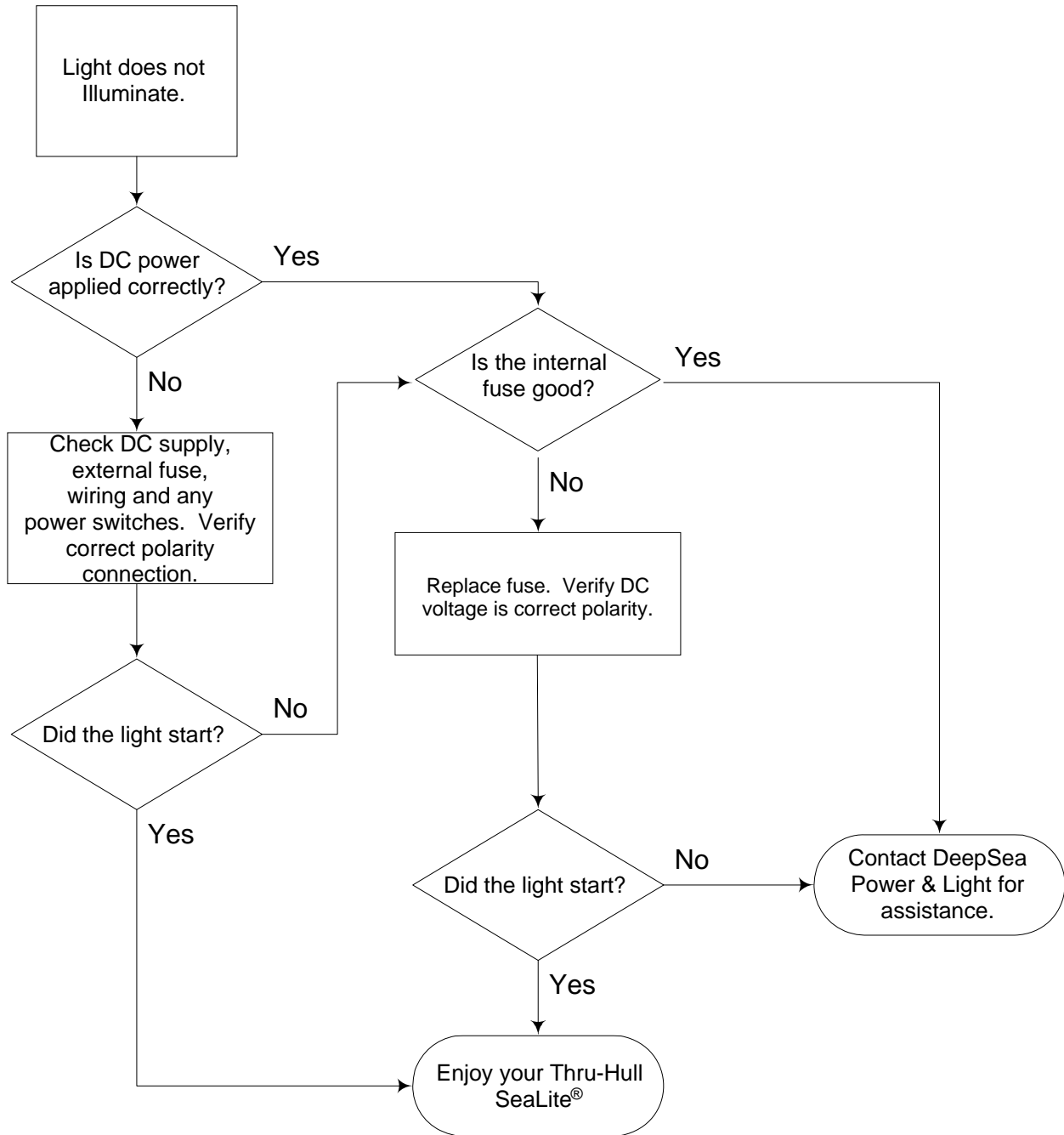

Internal Fuse Replacement



DANGER! Disconnect the DC power before attempting to service the light. Servicing a live light can result in electrocution, fire, personal injury and even death.

1. Disconnect DC power to the light.
2. Loosen the cable seal nut (Heyco) on the end of light fitting inside boat. Wiggle cable and push in slightly to be certain cable is loose from cable seal nut.
3. With the cable seal nut loosened, start unscrewing the retaining nut (counter clockwise).
4. As the retaining nut is unscrewed, the endcap will be pushed back. As it is, push the cable into endcap gently.
5. When the retaining nut is loose, carefully remove the endcap while pushing in cable so that the cable does not disconnect.
6. Use a digital meter to check the fuse (See Figure 1).



Fig. 1

7. If the fuse is open, replace with an 8 amp fuse.
8. Reassemble the endcap to the fitting and tighten the retaining nut. The inner o-ring is for sealing, so be sure it is clean and without debris. The outer o-ring and the retaining nut is only for vibration lock, not for sealing. The retaining nut is fully installed when this o-ring is not visible.
9. Be certain the outer jacket of the cable is fully within the body of the cable seal nut, and protrudes slightly within the interior of the 18 LED Thru-Hull SeaLite. Tighten the cable seal nut and tug on the cable lightly. When the seal nut is fully engaging the cable jacket, the cable will not pull loose or move.
10. Reconnect DC power to the light.
11. Test light operation.

Replacing Driver Assembly

1. Ensure the 18 LED Thru-Hull SeaLite® fitting is cool.
2. Prepare a clean surface near the thru-hull fitting. You will need a clean surface on which to set the replacement driver assembly. A pad made from several paper towels covering a dry, clean surface works well.
3. Have a small (1/8") flat blade screwdriver and a 5/32" Allen hex wrench within easy reach of where you will work.
4. Ensure that the DC power is turned off. Disconnect the light's power cable from DC power.
5. Refer to the assembly and detail drawings on page 20 and 21.
6. Loosen the Heyco connector on the endcap assembly, to loosen the grip on the wire.
7. Unscrew the endcap assembly metal locking ring.
8. Slowly lift the endcap assembly a short distance away from the fitting. Remove the two wire quick disconnects on the inner endcap. Set aside.
9. Using the small flat blade screwdriver, remove the spiral snap ring holding the inner endcap in the fitting.
10. Remove the inner endcap.
11. Using the small flat blade screwdriver, remove the inner split retaining ring.



Caution! In the next step, there are two plungers (one brass, the other plastic) in the side of the heat sink that are loose in a cross hole. These may slip out of the driver heat sink assembly when it is removed from the flanged housing. These are needed to clamp the driver heat sink in place on final assembly. You'll want to hang onto these, and not let them fall into the bilge.

12. Insert the 5/32" Allen hex wrench into the Allen screw located in the center of the driver board heat sink. Turn counterclockwise to loosen, about two turns. Gently rock the driver board to loosen the side clamping plungers. Gently pull and slide the driver clear of the fitting, and capture the 2 small plungers (one brass, the other plastic) that may fall out of the side of the heatsink. Save these for step 15.
13. The old driver assembly and desiccant packet should be disposed of appropriately.
14. Inspect the inner diameter of the fitting for any debris. If any contaminants are found, clean with reagent grade (high purity) isopropyl alcohol. Dry thoroughly using canned air such as Dust-Off®.
15. Begin reassembling the light by checking the plastic clamp plunger is visible on the side of the driver board heat sink. Align the pins of new driver assembly with holes in LED heatsink plate inside the fitting. Gently insert driver assembly into the fitting and make sure it is firmly seated.
16. Insert the 5/32" Allen hex wrench into the Allen screw located in the center of the driver board heat sink. Turn clockwise to tighten snugly. The side plastic plunger is forced outward, pressing the heat sink against the opposite side wall of the housing.
17. Drop a new desiccant packet in the fitting, next to the driver.

18. Reinsert the spilt retaining ring.
19. Insert the replacement inner endcap by aligning notches on driver assembly and inner endcap and pressing down firmly.



Caution! Do not pinch the wires when inserting the inner endcap.

20. Reinsert spiral snap ring. Using a small screw driver is helpful to ensure the spiral snap ring is seated properly in the fitting groove.
21. Attach the two quick disconnects on the inner endcap.
22. Screw on endcap assembly metal locking ring.
23. On the endcap assembly, tighten the Heyco connector to grip the cable. Be careful not to overtighten.



If a new driver assembly is not available to immediately replace the old assembly, cover the fitting opening with several layers of saran wrap cover to help keep the fitting clean inside. Use good quality black electrical tape (such as Scotch 33 or 38) to secure saran wrap in place. Remove the saran wrap cover before installing a new driver assembly.

24. Ensure that the DC power is turned off. Refer again to the wiring diagrams on page 18 and connect the light's cable to a properly sized in-line fuse or circuit breaker. Consult a professional marine electrician.



WARNING! DO NOT connect 18 LED Thru-Hull SeaLite® to AC voltage.

25. At this point, the 18 LED Thru-Hull SeaLite® can be tested by energizing the light.

How to Arrange for Repairs

Please contact DeepSea Power & Light, Inc. (DeepSea) at 1-800-ITS-DSPL (1-800-487-3775) to secure an RMA number prior to returning your light for repair. Mark the outside of the shipping container with the RMA number. This allows us to process your package as quickly as possible, and insures that the repair department is alerted of its arrival.



WARNING! ALWAYS remove power to any light that is not operating properly to reduce the risk of electrically driven corrosion failure of the fitting.

Warranty Repairs

Warranty repairs must be shipped to DeepSea freight prepaid. If you are shipping from outside of the U.S., for U.S. Customs purposes please mark the shipment as an underwater light(s) returning to the manufacturer for repair. DeepSea will perform a full evaluation upon receipt. If the problem is determined to be a warranty issue, DeepSea will repair or replace the unit at no charge. DeepSea will also pay outgoing ground transportation. See limited warranty for exceptions.

Non-Warranty Repairs

A diagnostic charge will be assessed for all repair estimates. This fee will be applied against any repair charges that are approved by

customer. If repairs are not approved then customer will be charged for 1 hour diagnostics and the shipping expense to return unit to them. The prices of component parts do not include labor charges. Labor is billed at a minimum of 1 hour, with additional labor billed in half-hour increments.

Limited Warranty

DeepSea warrants all of its products, unless otherwise noted, to be free from defects in workmanship and materials for a period of one year from the date of original purchase.

Internal electronic components are warranted for 90 days from the date of shipment from the factory, if they have been properly used.

DeepSea is not responsible for warranty service should the product fail to be properly maintained or fail to function properly as a result of misuse, abuse, improper installation, neglect, improper shipping, corrosion, damage caused by disasters such as fire, flood, and lightning, or unauthorized repair or modifications.

Should your DeepSea product prove defective during the warranty period, promptly notify DeepSea to obtain an RMA number, and return the product, freight prepaid (by Customer) with the RMA number noted on the outside of the box. If you are shipping

from outside of the U.S., for U.S. Customs purposes please mark the shipment as an underwater light(s) returning to the manufacturer for repair. DeepSea will, at its option, repair or replace the product or defective portion without charge for parts or labor, or, at DeepSea's option, refund the purchase price. DeepSea will pay for ground transportation to the customer on warranty repairs. Products repaired or replaced under this warranty shall be warranted for the unexpired portion of the warranty applying to the original product(s).

The sole obligation of DeepSea shall be to repair, replace, or refund parts which have been proved defective. This does not include any other associated costs, such as the cost of removal of the defective part(s), installation costs, labor costs, travel costs, or consequential damages of any kind. Under no circumstances shall the Buyer be entitled to recover any incidental damages as that term is defined in Commercial Code §2715.

No warranty or affirmation of fact, express or implied, other than as set forth in the limited warranty statement above is made or authorized by DeepSea. DeepSea disclaims any liability for product defect claims that are due to product misuse, improper product selection, or misapplication. Any liability for consequential and incidental damages is expressly disclaimed. DeepSea's liability in all events is limited to, and shall not exceed, the purchase price paid.

Appendix A – Drawings

List of Figures

Figure 1 – Wiring Diagram	19
Figure 2 – Assembly Drawing	20
Figure 3 – Detail: Driver Heatsink Clamp cutaway	21

Figure 1 - Wiring Diagram

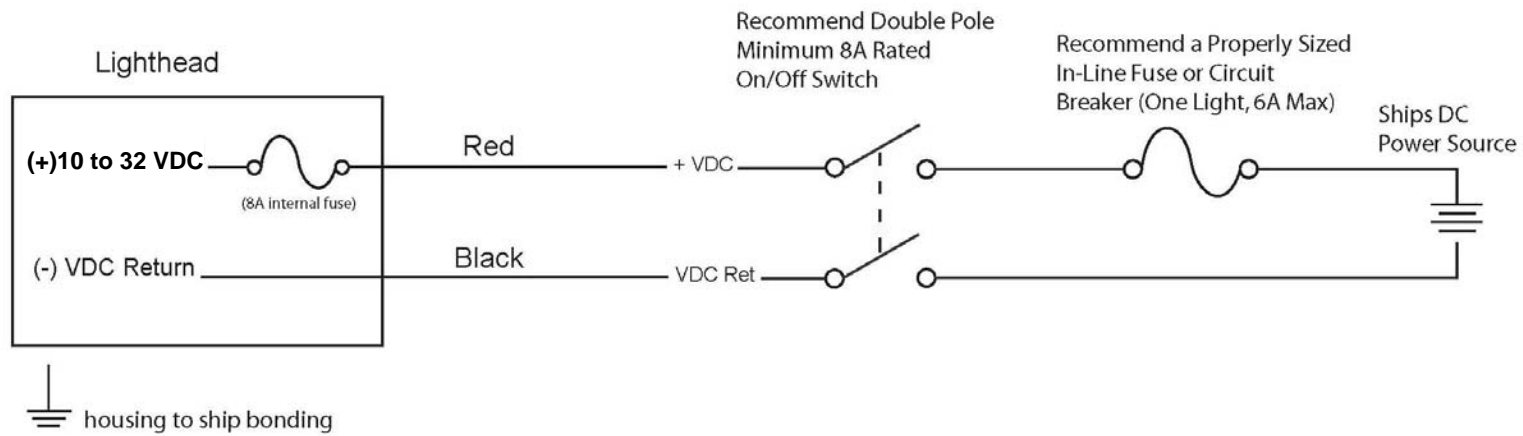

 Note: Proper grounding is required to prevent corrosion of light fixture. A green screw on the jacking ring is provided for appropriate grounding. Installation by a qualified boatyard is recommended.

Figure 2 – Assembly Drawing

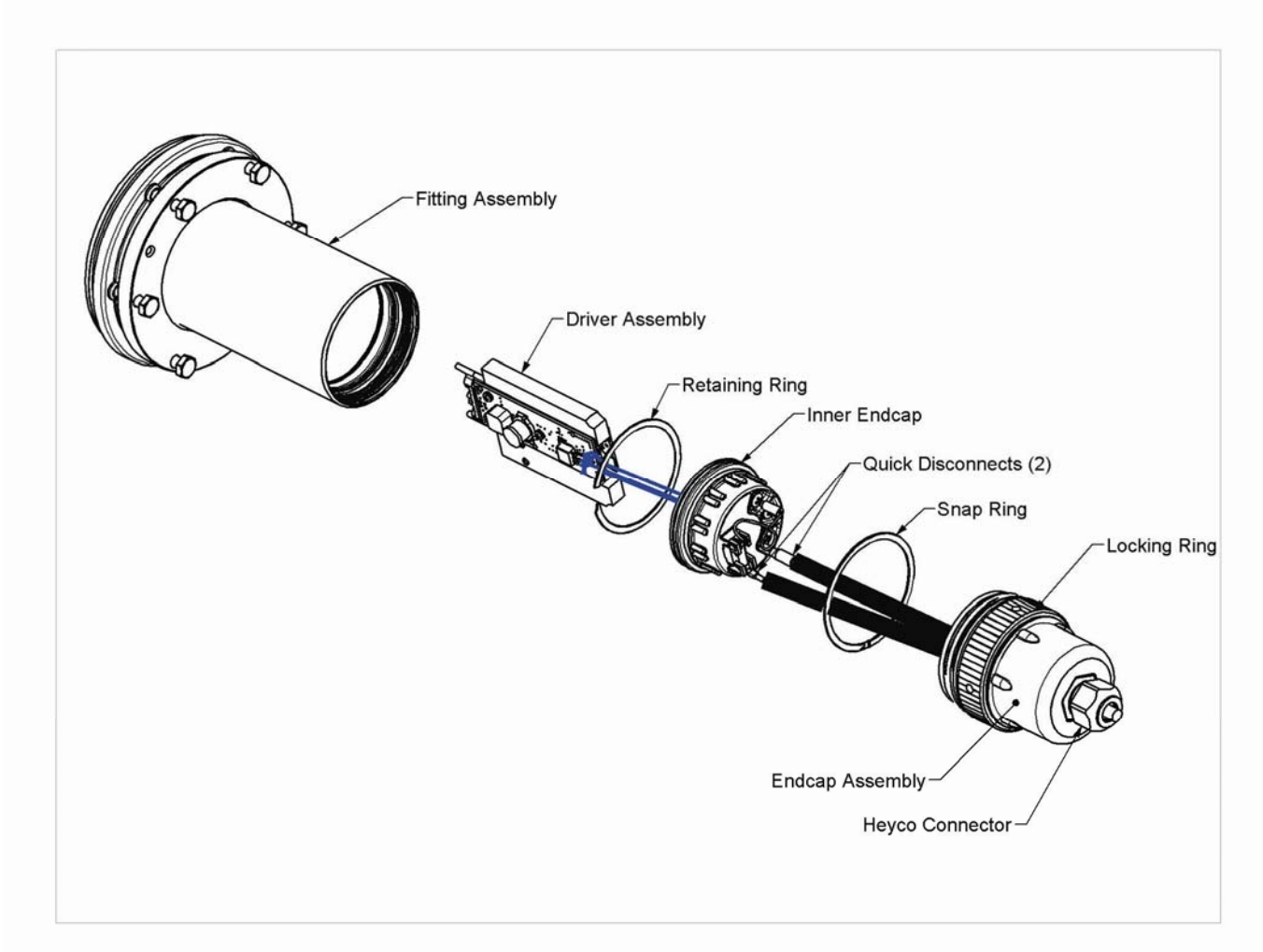

Figure 3 – Detail: Driver Heatsink Clamp Cutaway

