

MiniLED S/D Thru-Hull SeaLite[®]

U.S. Patent No. 7,044,623

Installation, Operation, Maintenance and Safety Instructions

MiniLED Manual P/N 712-013-601-0A



4033 Ruffin Rd., San Diego, CA 92123-1817, Phone: (858) 576-1261, Fax: (858) 576-0219
E-mail: info@deepsea.com Web: www.deepsee.com

Table of Contents

UNPACKING AND INSPECTION	3
MANUAL INFORMATION	4
 READ BEFORE USING.....	5
FEATURES.....	6
SPECIFICATIONS	7
PARTS OF THE MINILED S/D THRU-HULL SEALITE®	8
INSTALLATION & OPERATING INSTRUCTIONS.....	9
MAINTENANCE AND TROUBLESHOOTING	11
Troubleshooting Guide	11
Replacing LED Cartridge Assembly	12
HOW TO ARRANGE FOR REPAIRS	13
Warranty Repairs	13
Non-Warranty Repairs	13
LIMITED WARRANTY	13
APPENDIX A – DRAWINGS	14
Figure 1 - Wiring Diagram.....	15
Figure 2 – Assembly Drawing.....	16

Congratulations on the purchase of your MiniLED S/D Thru-Hull SeaLite®! DeepSea Power & Light has been supplying underwater lights for industrial and research applications for over 25 years, and our line of SeaLite® products have set the standard for durability and performance in every industry where they are used. Your MiniLED S/D Thru-Hull SeaLite® has been rigorously tested, and the quality and performance of your product comes with the full confidence and backing of DeepSea Power & Light. As a measure of that confidence, your MiniLED S/D Thru-Hull SeaLite® comes with a full one-year warranty against defects in workmanship and materials. A complete copy of the warranty statement can be found on page 13.

Unpacking and Inspection

Before the MiniLED S/D Thru-Hull SeaLite® is packaged for shipment it is rigorously tested and inspected. The product is then carefully packaged to withstand the rough handling that can be anticipated during shipment. DeepSea Power & Light engages only reputable shipping companies to handle our merchandise, so it is rare that a product is damaged in shipment. Upon arrival, carefully check the light for damage. If the product is damaged in any way, immediately file a damage claim with the carrier. In addition, mail or fax a copy of the claim to DeepSea Power & Light and notify your sales representative. We will do everything in our power to expedite processing of the claim.

MiniLED S/D Thru-Hull SeaLite®	
Record the Serial Number of your unit below and retain for your records.	
Serial Number	

Manual Information

The following symbols and terms are used throughout this manual to emphasize important safety information.



is used to highlight important information.



Caution! is used to indicate directions that, if not followed correctly, can result in equipment damage.



WARNING! is used to indicate directions that, if not followed correctly, can result in personal injury and/or serious equipment damage.



DANGER! is used to warn of directions that, if not followed correctly, can result in serious personal injury or death.

 **Read Before Using**

1. MiniLED S/D Thru-Hull SeaLite® are designed for installation on fiberglass and wooden hulled boats only.
2. MiniLED S/D Thru-Hull SeaLite® should never be installed on a vessel while the vessel is in the water.
3. The wall thickness surrounding any part of the thru-hull fitting should not be less than 0.25 in (6.35 mm) and not more than 3.25 in (8.26 cm).
4. Only qualified technicians who have experience with the installation of thru-hull fixtures should install MiniLED Thru-Hull SeaLites®.
5. MiniLED S/D Thru-Hull SeaLite® must be electrically joined to the vessel's grounding and cathodic protection system. Failure to properly ground this fixture may result in catastrophic failure due to CORROSION, which in turn may lead to injury, damage or loss of property and loss of life.



WARNING! It should be noted that all metal parts will corrode in salt water. Corrosion of any metal will be especially aggressive if installation is improper, if bonding is improper, or if stray currents are active in the vicinity of the boat. MiniLED S/D Thru-Hull SeaLite® are warranted to be free from defects in material and workmanship, but this does not extend to being completely free from corrosion since the primary factors affecting corrosion are outside of the scope of material and workmanship of the light itself.

6. Once the fixtures have been installed on the vessel they should be inspected every 6 months for:
 - a. Corrosion and damage. Any fixture showing signs of corrosion or other physical damage should be removed from service immediately.
 - b. Signs of leakage and water entry. Any fixture showing signs of leakage or water entry should be removed from service immediately.
 - c. Blackened or opaque ports. The light should never be operated with a blackened or opaque port. If the port is blackened the fixture should not be operated and should be inspected for internal damage.
 - d. Marine growth on the port. Any marine growth should be removed from the port in order to allow heat and light to exit the fixture. Use of a soft brush or non-metallic household dishwashing scrubber is recommended to prevent damage to the fixture and port. If the growth cannot be removed using a soft brush, a professional hull cleaner should be consulted.

Features

Several features come together in the MiniLED S/D Thru-Hull SeaLite® to create a unit that offers amazing light output, is extremely rugged and most importantly, safe.

- **Ultra Long Life** – With an average life of 50,000 hours, the MiniLED S/D Thru-Hull SeaLite® will provide many years of service. Unlike traditional lights, LEDs require no bulb maintenance!
- **High Color Temperature LEDs for Enhanced Effect** – Your MiniLED S/D Thru-Hull SeaLite® projects a white, bright light from its 6,000°K color temperature LEDs. Blue and green LED color options are available.
- **316 Stainless Steel Construction** – The thru-hull fitting is manufactured from 316 Stainless Steel for enhanced corrosion protection.
- **High Performance Polymer Port** – Our exclusive polymer port will withstand accidental impact better than glass, and is less likely to be damaged by hull cleaning equipment.
- **Water-tight Housing** – Front and rear seals provide an extra measure of safety. In the unlikely event that the port is broken, the rear seals will contain flooding to the inside of the thru-hull fitting. No water is allowed into the vessel.
- **Integrated Driver Board** – The driver board and all electronic circuitry is integrated into the watertight housing, protecting it from the elements and simplifying installation. Simply run the power cable from the back of the light to your power source.
- **Serviceable From Inside The Boat** – Once installed, the LEDs and driver can be accessed thru the back of the light. Hauling out is not required!
- **Thermal Compensation Circuitry** – Special circuitry regulates the temperature of the LEDs, improving the life of the LEDs and allowing the light to be run in air.
- **Fish Attracting Strobe Circuitry** – Allows the light to double as a fish attracting strobe light.
- **Dimming Circuitry** – Allows the light output to be adjusted to set the perfect mood.

Specifications

Light Specifications

MECHANICAL

Housing Material:	316L Stainless Steel
Pressure Tested To:	100 PSI
Size:	
Length:	6.02 in. (15.29 cm)
Diameter:	
Thru-Hull Fitting:	1.245 in. (3.16 cm)
Outer Flange (1/4 in. thick):	1.965 in. (4.99 cm)
Weight:	15.00 oz. (0.43 kg)
Lens:	High performance polymer
Cable Length:	15' (4.57 m) standard (longer available on request)
Recommended Hull Thickness:	
Minimum:	0.25 in. (6.35 mm)
Maximum:	3.50 in. (8.26 cm)

LAMP

Type:	LED (White, Blue, or Green)
Rated Average Life:	50,000 hours
Color Temperature:	6,000° K
Beam Angle:	30° center spot within 30° flood

OPERATING

Warm Up / Re-strike Time	Instantaneous
Minimum Operating Temperature:	-22° F (-30° C)

ELECTRICAL

Input Voltage:	10-32 VDC
Input Current:	1 A at 12 VDC
Input Power:	15 Watts
Strobe Input:	Active ≥2.0 VDC In-active ≤0.3 VDC
Dimming Input:	50K ohm 10 turn potentiometer or 0 to 5 VDC (max 32 VDC)

Parts of the MiniLED S/D Thru-Hull SeaLite®

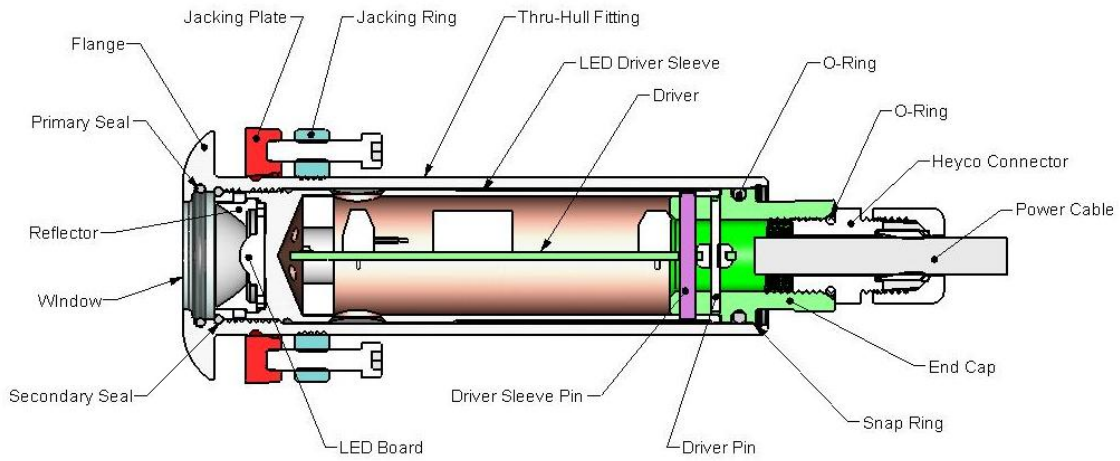

Installation & Operating Instructions



Your MiniLED S/D Thru-Hull SeaLite® is designed for installation in fiberglass and wooden hulled boats only.



To ensure no damage has occurred during shipping, power up the unit BEFORE drilling any holes in the boat. Before drilling any holes in the transom, energize the light using the intended 10-32 VDC power source to ensure proper operation.



Caution! For hulls constructed with Divinycell® or similar foam cores, please consult the boat manufacturer, a professional boat builder, or your boat dealer for specific procedures to use when installing hull-penetrating fixtures. In general, the exposed surfaces of the internal core must be protected using a fiberglass resin or an epoxy compatible with the hull material to form a solid, sealed surface from the outside to the inside of the hull. This material must be rated to no less than 176°F (80°C).

MiniLED S/D Thru-Hull SeaLite® are typically mounted horizontally in the transom, however, they can also be installed horizontally through the side of the hull and vertically down through the hull. Performance for vertical installations varies depending on the installation and water conditions. While vertical installations work successfully much of the time, there are conditions which can cause the light to run hotter than normal. In particular, down pointing lights in still water are apt to get air bubbles on the flange and window that degrade heat transfer. If a down pointing light is running hotter than normal, the thermal compensation circuitry will dim down the LEDs to regulate the temperature.

1. The MiniLED S/D Thru-Hull SeaLite® should be mounted on a flat part of the hull with the center of the fitting at least 10" (254 mm) below the waterline. The fitting's flange should not extend beyond the flat surface on which it will be mounted.
2. Before cutting the hole, ensure that there will be a minimum clearance of 8.5" (216 mm) on the inside of the hull, inboard of the hole. This clearance is necessary to allow enough room to service the light from inside the boat.
3. On the outside of the hull, mark the center of the hole to be made in the hull. Draw a 2" (51 mm) circle around the center mark and verify that the area of the hull within is flat.
4. Cut or drill a 1.25" (32 mm) diameter hole in the hull.
5. Test fit the thru-hull fitting in the hole by sliding the fitting in from the outside of the hull.
6. Using the circle drawn on the hull in step 3 as a guide, coat the area around the hole with 3M® 4200 sealant. Also, coat the flange and the portion of the body of the fixture that will extend thru the hull with 3M® 4200 sealant and slide the fixture into the hole.



Caution! Be careful not to over-tighten the bolts when installing the jacking ring. Doing so may squeeze the sealant out from under the fitting flange.

7. On the inside of the hull, slide the jacking plate and jacking ring assembly over the thru-hull fitting to the inside of the hull. Back the six 8/32 socket head cap screw in the jacking ring out so that their ends do not extend beyond the face of the ring. Thread the jacking ring onto the fitting until it bottoms against the jacking plate. Hand-tighten the six 8/32 socket head cap screws to approximately 5 in.-lbs.
8. Allow the sealant to dry (according to its instructions) and remove any excess.

9. After the sealant has dried, tighten the six 8/32 socket head cap screws head bolts to 36 in.-lbs (4 Nm).
10. Use the green screw terminal on the jacking ring to connect the fixture to the ship's bonding system. Failure to properly ground this fixture may result in catastrophic failure due to CORROSION, which in turn may lead to injury, damage or loss of property and loss of life.
11. DSP&L recommends that the flange of the thru-hull fitting be painted with anti-fouling paint after installation. In addition, spraying the end cap and the portion of the fitting inside the hull with WD-40 every two months will help keep the fitting looking new and free of corrosion.



Caution! The original cable provided with this light has been specifically chosen for this application. Substituting another cable may cause improper operation, shock hazard, interference with other equipment on the vessel, and can result in **damage that may not be covered under warranty**. Additional cable is available from DeepSea Power & Light, Inc. by calling 1-800-ITS-DSPL (1-800-487-3775).

12. Verify that the light's voltage rating and the voltage available on the vessel are compatible. Ensure that the DC power is turned off. Refer again to the wiring diagrams on page 15 and connect the light's cable to a properly sized in-line fuse or circuit breaker. Consult a professional marine electrician.



WARNING! DO NOT connect MiniLED S/D Thru-Hull SeaLite® to AC voltage.



NOTE: A control kit is available from DeepSea Power & Light that includes a toggle switch, potentiometer, and 5V regulator that can control the dimming and strobing features of up to 4 lights.

13. For the strobe feature, refer to the wiring diagram and connect the light to a sealed DPDT switch (not supplied) (Mouser p/n 633-S7A-RO & 608-1131/26). When activated, the light will strobe at a frequency of 5 Hz.
14. For the dimming feature, refer to the wiring diagram and connect the light to a 5K ohm 1 turn potentiometer (not supplied) (Mouser p/n 785-53C35K, 608-N9030 X 1/4, & 45KNo13-GRX) and a 5V regulator (not supplied) (Mouser p/n 511-L7805ABP). The potentiometer can be used to adjust the light output.



NOTE: If either the strobe feature or dimming feature is not used, tape off the wire to ensure it does not short to anything.

15. At this point, the MiniLED S/D Thru-Hull SeaLite® can be tested by energizing the light.
16. The MiniLED S/D Thru-Hull SeaLite® can function in water or in air. Thermal compensation circuitry regulates the temperature of the LEDs and will dim them down in the event that they get too warm. For example, lights mounted in the transom of a vessel may break the surface of the water while the boat is underway, causing the lights to run warmer than if they were completely submerged. If this is the case, the LEDs will be dimmed automatically to regulate the temperature.
17. If the light does not operate properly, please refer to the Troubleshooting Guide on page 11 to determine the cause of the malfunction.



WARNING! ALWAYS remove power to any light that is not operating properly to reduce the risk of electrically driven corrosion failure of the fitting.

Maintenance and Troubleshooting

Troubleshooting Guide

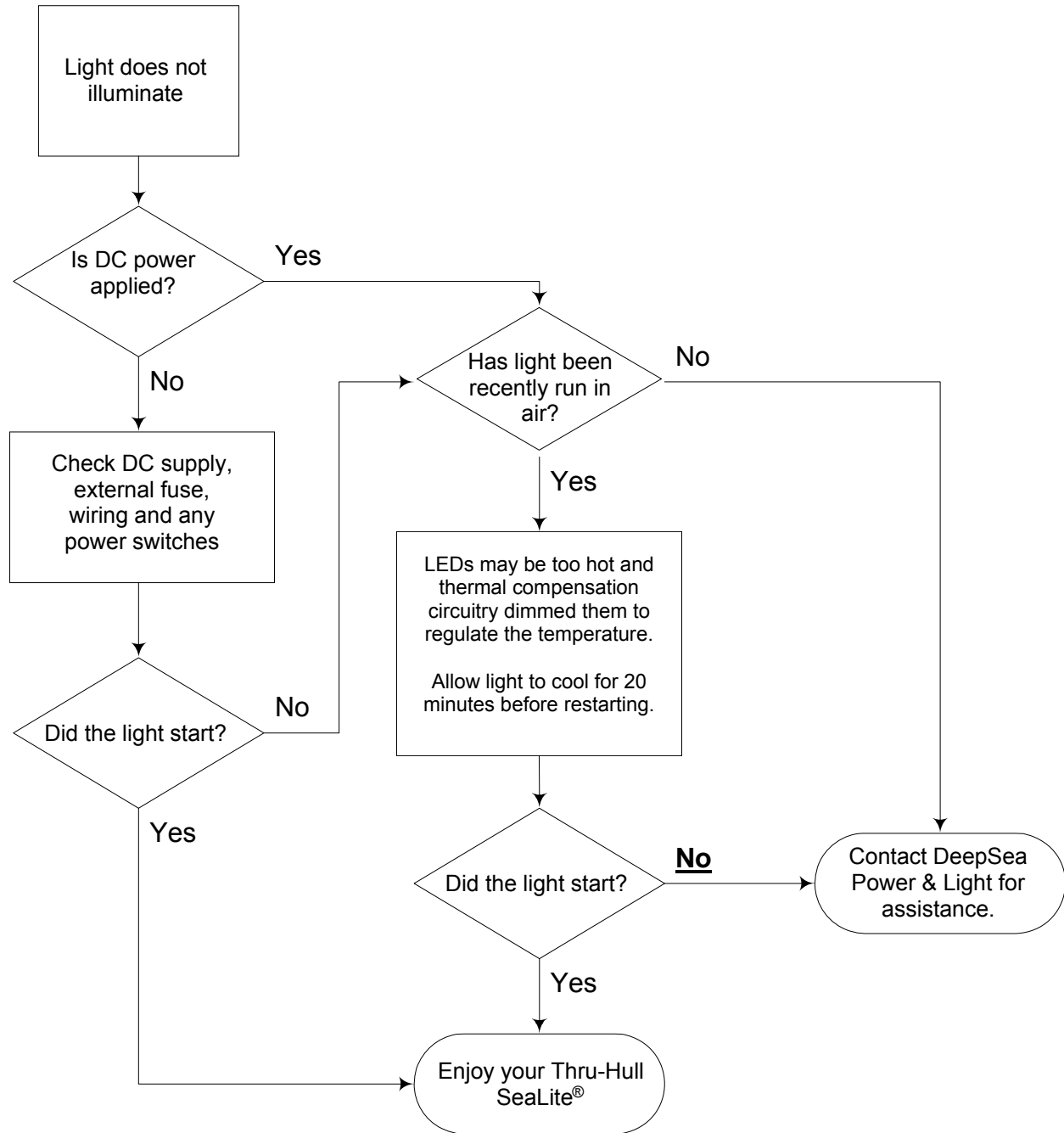

Replacing LED Cartridge Assembly

1. Ensure the MiniLED S/D Thru-Hull SeaLite® fitting is cool.
2. Prepare a clean surface near the thru-hull fitting. You will need a clean surface on which to set the replacement LED cartridge assembly. A pad made from several paper towels covering a dry, clean surface works well.
3. Have a small (1/8") flat blade screwdriver within easy reach of where you will work.
4. Ensure that the DC power is turned off. Disconnect the light's power cable from DC power and gather up the cable run.
5. Using the small flat blade screwdriver, remove the LED cartridge assembly snap ring. Refer to the assembly drawing on page 16.
6. Unthread the LED cartridge assembly and slide it clear of the fitting assembly.
7. The old LED cartridge assembly and power cable should be disposed of appropriately.
8. Inspect the inner diameter of the fitting and the inner surface of the port for any debris. If any contaminants are found, clean with reagent grade isopropyl alcohol. Dry thoroughly using canned air such as Dust-Off®.
9. Begin reassembling the light by gently inserting new LED cartridge assembly into the fitting assembly and thread it into place. Note, the endcap is made of Delrin. Hand tight should be all that is required to ensure a good seal. If a wrench is needed, be careful not to strip or break the endcap.
10. Reinsert the LED cartridge assembly snap ring.



If a new LED cartridge assembly is not available to immediately replace the old assembly, cover the fitting opening with several layers of saran wrap cover to help keep the fitting clean inside. Use good quality black electrical tape (such as Scotch 33 or 38) to secure saran wrap in place. Remove the saran wrap cover before installing a new LED cartridge assembly.

11. Ensure that the DC power is turned off. Refer again to the wiring diagrams on page 15 and connect the light's cable to a properly sized in-line fuse or circuit breaker. Consult a professional marine electrician.



WARNING! DO NOT connect MiniLED S/D Thru-Hull SeaLite® to AC voltage.

12. At this point, the MiniLED S/D Thru-Hull SeaLite® can be tested by energizing the light.

How to Arrange for Repairs

Please contact DeepSea Power & Light, Inc. (DeepSea) at 1-800-ITS-DSPL (1-800-487-3775) to secure an RMA number prior to returning your light for repair. Mark the outside of the shipping container with the RMA number. This allows us to process your package as quickly as possible, and insures that the repair department is alerted of its arrival.



WARNING! ALWAYS remove power to any light that is not operating properly to reduce the risk of electrically driven corrosion failure of the fitting.

Warranty Repairs

Warranty repairs must be shipped to DeepSea freight prepaid. If you are shipping from outside of the U.S., for U.S. Customs purposes please mark the shipment as an underwater light(s) returning to the manufacturer for repair. DeepSea will perform a full evaluation upon receipt. If the problem is determined to be a warranty issue, DeepSea will repair or replace the unit at no charge. DeepSea will also pay outgoing ground transportation. See limited warranty for exceptions.

Non-Warranty Repairs

A diagnostic charge will be assessed for all repair estimates. This fee will be applied against any repair charges that are approved by customer. If repairs are not approved then customer will be charged for 1 hour diagnostics and the shipping expense to return unit to them. The prices of component parts do not include labor charges. Labor is billed at a minimum of 1 hour, with additional labor billed in half-hour increments.

Limited Warranty

DeepSea warrants all of its products, unless otherwise noted, to be free from defects in workmanship and materials for a period of one year from the date of original purchase.

Internal electronic components are warranted for 90 days from the date of shipment from the factory, if they have been properly used.

DeepSea is not responsible for warranty service should the product fail to be properly maintained or fail to function properly as a result of misuse, abuse, improper installation, neglect, improper shipping, corrosion, damage caused by disasters such as fire, flood, and lightning, or unauthorized repair or modifications.

Should your DeepSea product prove defective during the warranty period, promptly notify DeepSea to obtain an RMA number, and return the product, freight prepaid (by Customer) with the RMA number noted on the outside of the box. If you are shipping from outside of the U.S., for U.S. Customs purposes please mark the shipment as an underwater light(s) returning to the manufacturer for repair. DeepSea will, at its option, repair or replace the product or defective portion without charge for parts or labor, or, at DeepSea's option, refund the purchase price. DeepSea will pay for ground transportation to the customer on warranty repairs. Products repaired or replaced under this warranty shall be warranted for the unexpired portion of the warranty applying to the original product(s).

The sole obligation of DeepSea shall be to repair, replace, or refund parts which have been proved defective. This does not include any other associated costs, such as the cost of removal of the defective part(s), installation costs, labor costs, travel costs, or consequential damages of any kind. Under no circumstances shall the Buyer be entitled to recover any incidental damages as that term is defined in Commercial Code §2715.

No warranty or affirmation of fact, express or implied, other than as set forth in the limited warranty statement above is made or authorized by DeepSea. DeepSea disclaims any liability for product defect claims that are due to product misuse, improper product selection, or misapplication. Any liability for consequential and incidental damages is expressly disclaimed. DeepSea's liability in all events is limited to, and shall not exceed, the purchase price paid.

Appendix A – Drawings

List of Figures

Figure 1 - Wiring Diagram	15
Figure 2 – Assembly Drawing	16

Figure 1 - Wiring Diagram

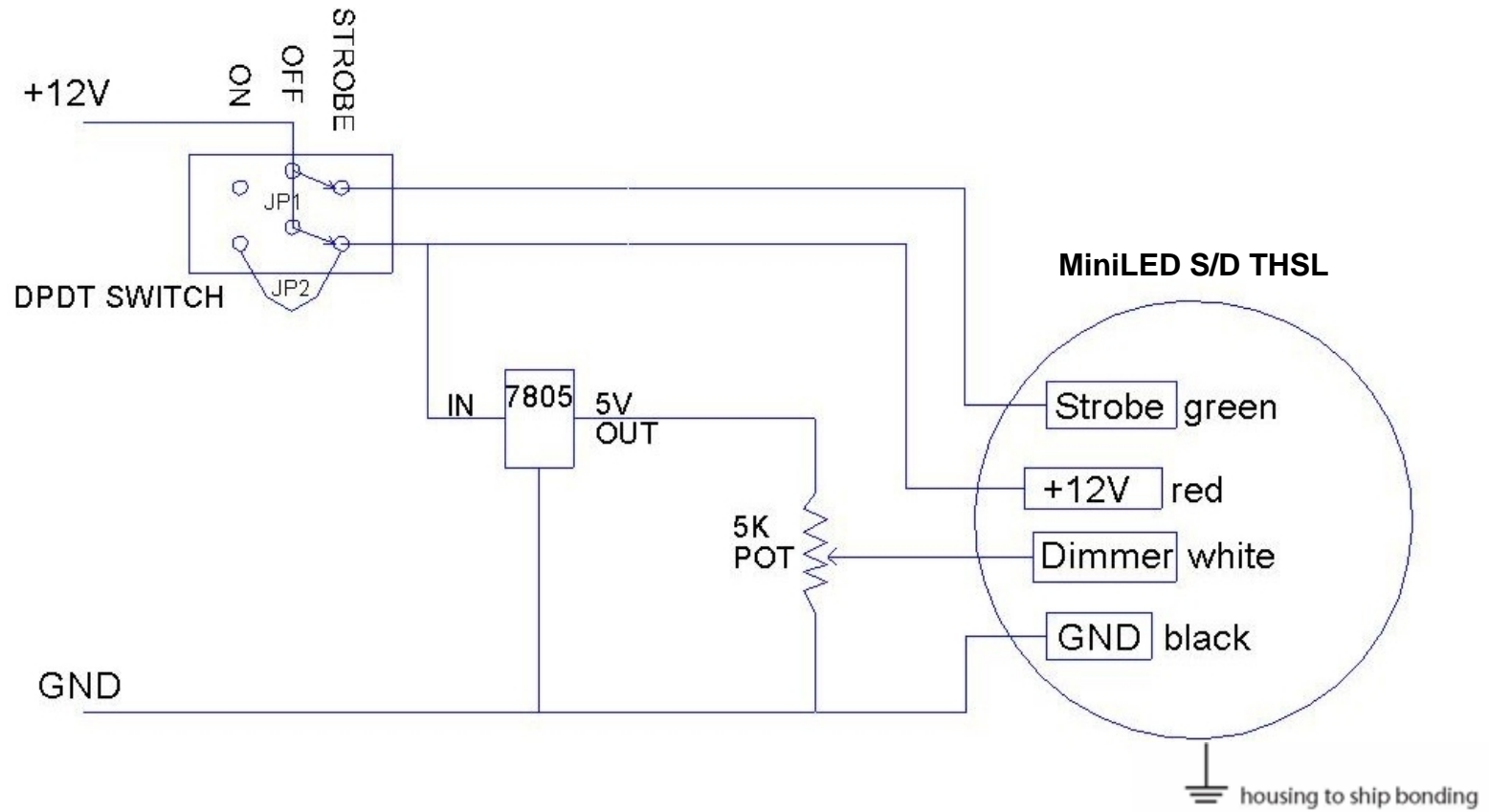

⚠ Note: Proper grounding is required to prevent corrosion of light fixture.
A green screw on the jacking ring is provided for appropriate grounding.
Installation by a qualified boatyard is recommended.

Figure 2 – Assembly Drawing

